

# Baytex Manufacturing Co Ltd

## Keder Feeder - Alispan

### Rafter Modification



1. Cut Away Top Tab of End Eave Face Plate.
  - Use grinder with 1.5mm cutting disc.
  - to allow full access to top centre slot of rafter extrusion.
  - Spray cut edge with DuraGalv. for rust protection.
2. Drill Ø8mm Hole 130mm up, centre top only.
  - to allow pin to retain Keder Feeder.
  - drilling jig available for a fee if required.

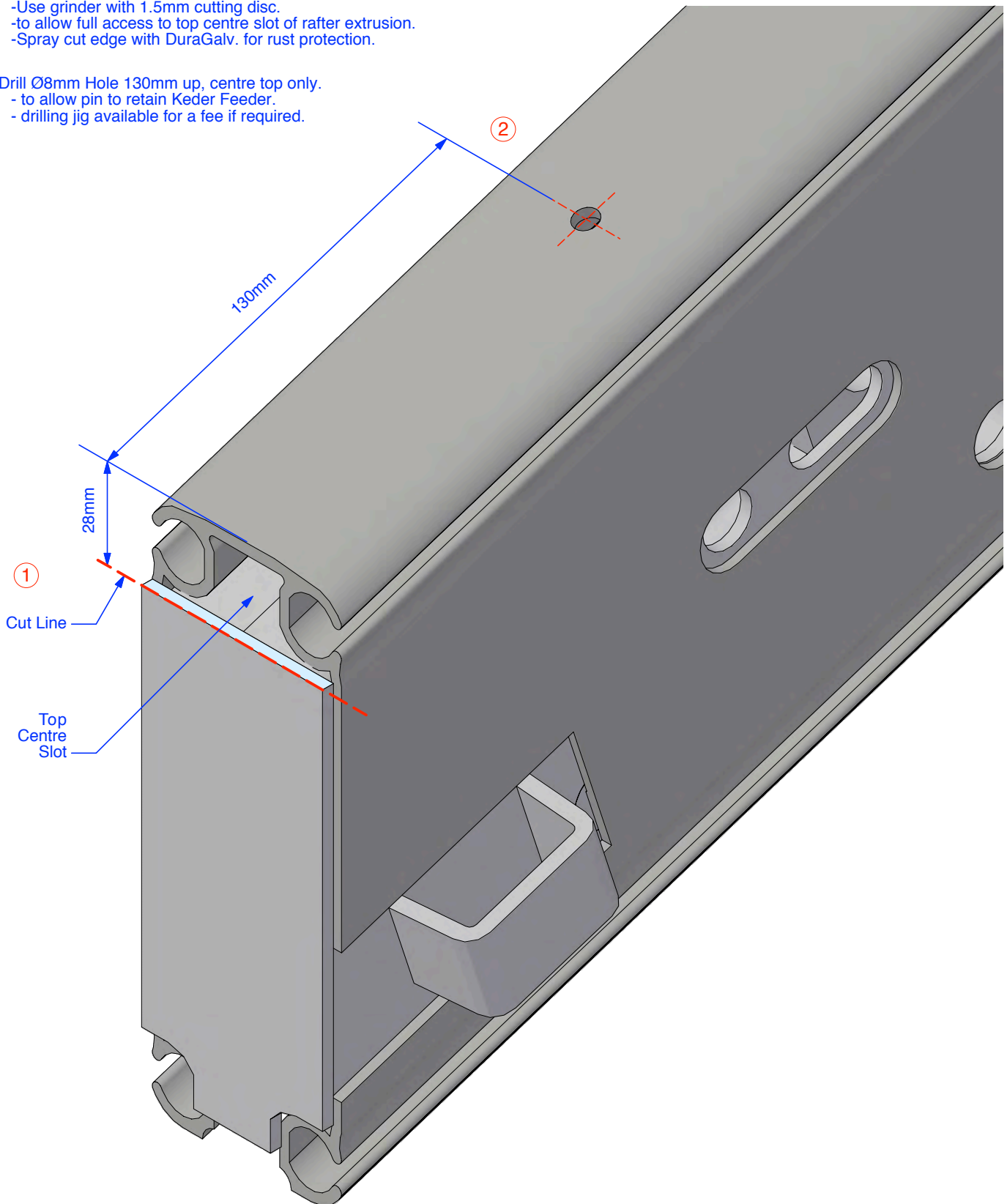

Alispan Rafter Eave End