

FETE 3mx6m

Assembly Instructions

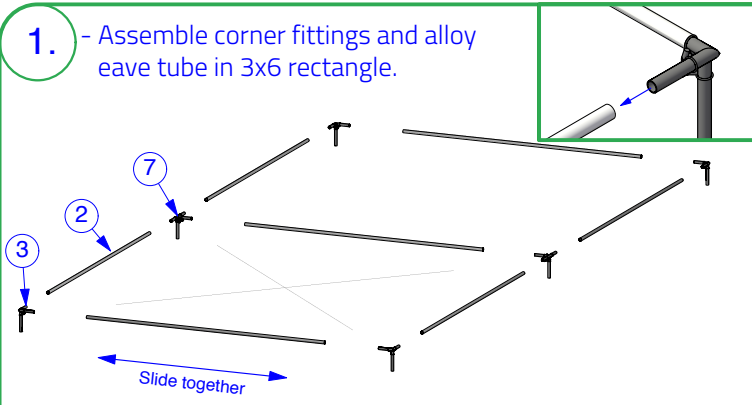

1. - Assemble corner fittings and alloy eave tube in 3x6 rectangle.



2. - Attach brace cables over corner fitting hook.
- Lift last corner for top wire.

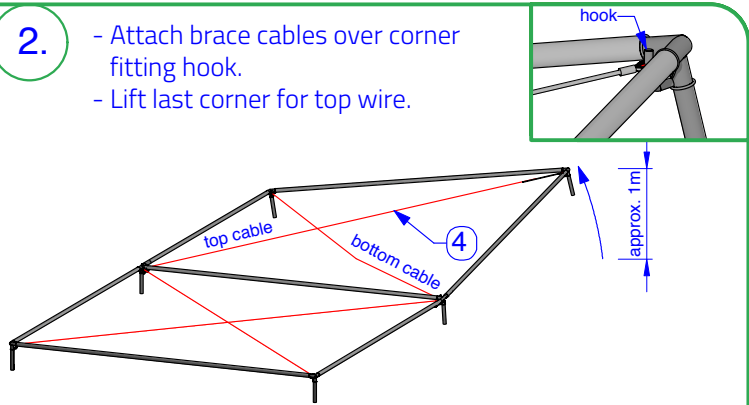

3. - Fit roof fabric over assembled frame.

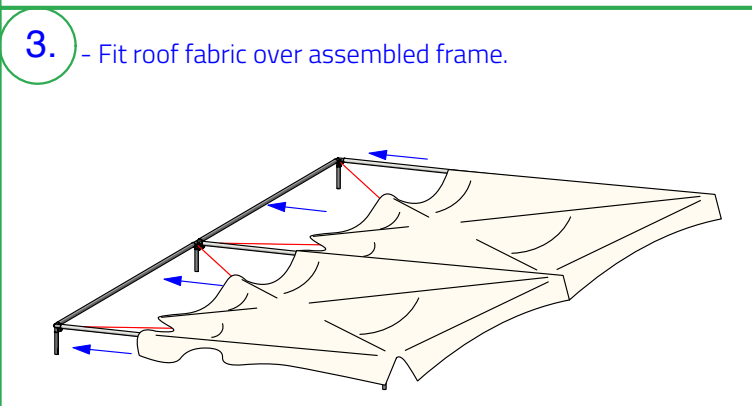

4. - Pull web loop over each corner fitting lug.

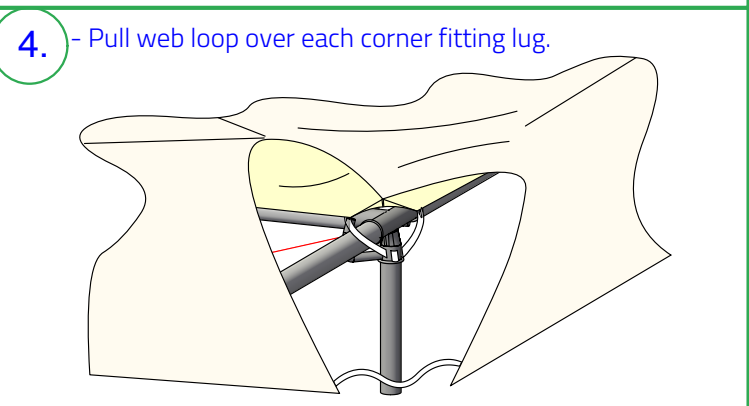

5. - Button lock base fitting to leg alloy.
- Raise side onto legs with erecting fork at centre of eave.
- Hook web straps to base fitting loop.

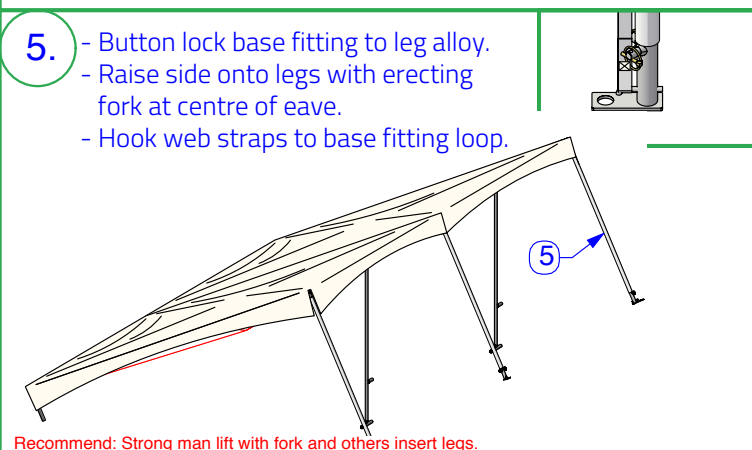

6. - Insert centre pole cap into roof apex.
- Roll centre pole on top cable to the centre where cables cross.
- Pull lower cable under to lock into centre pole roller fitting.

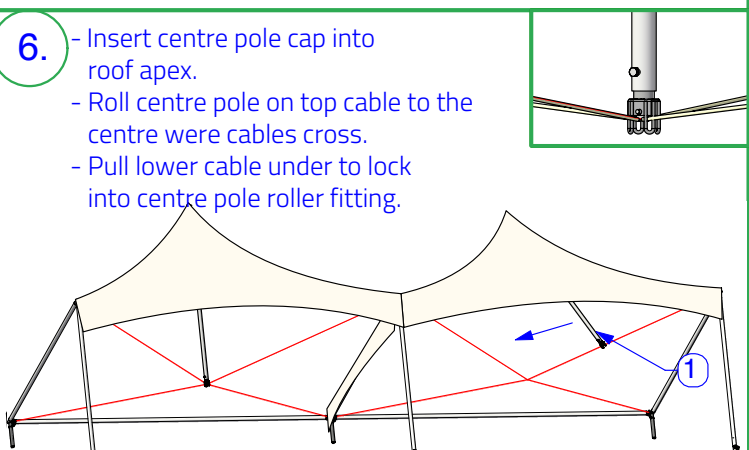

7. - Raise onto legs with erecting fork at centre of eave.
- Secure straps to base feet.
- Tension corners evenly with straps.

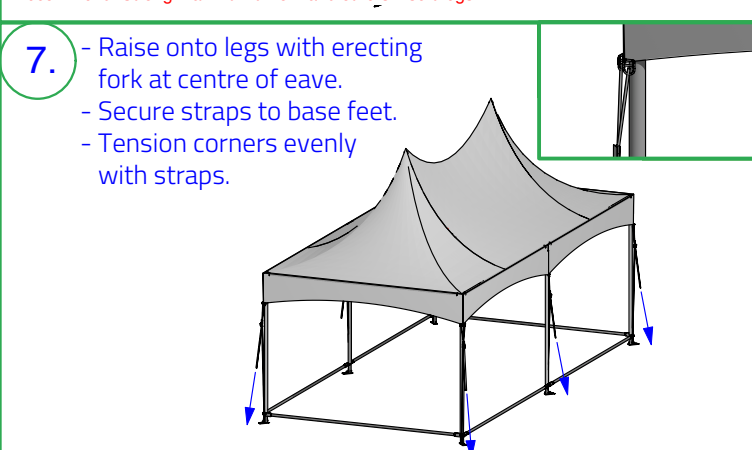

8. - Peg base feet to ground.
- Base alignment for base rails outside.

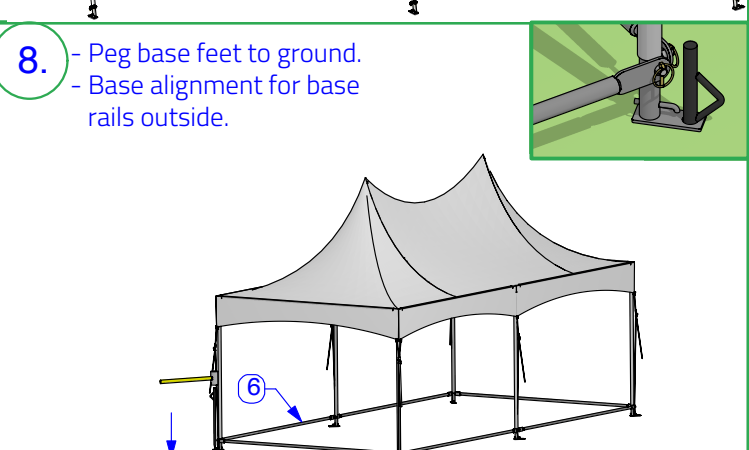

Fete marquees must be securely fixed down at all times.
Minimum hold down force for each leg is 250kgs.

Baytex
Ph: 07 579 0190
info@baytex.co.nz